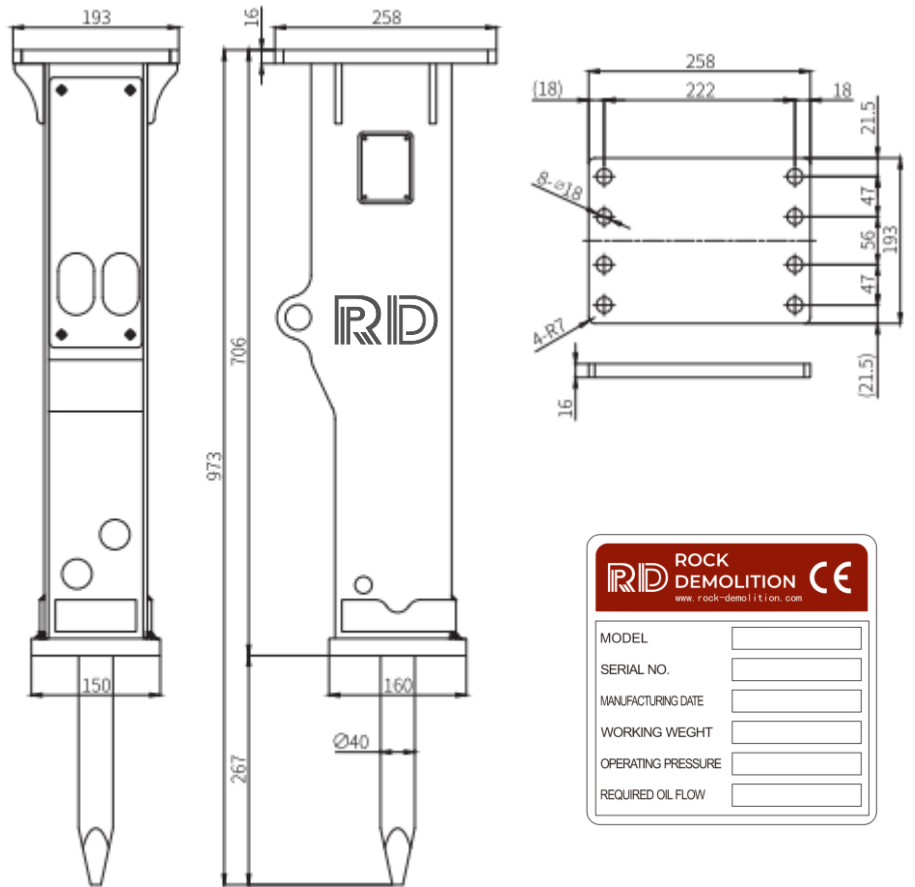

**RD-40**

RD ROCK DEMOLITION	
www.rock-demolition.com	
MODEL	<input type="text"/>
SERIAL NO.	<input type="text"/>
MANUFACTURING DATE	<input type="text"/>
WORKING WEIGHT	<input type="text"/>
OPERATING PRESSURE	<input type="text"/>
REQUIRED OIL FLOW	<input type="text"/>

Spécifications technique

FRANCAIS	ENGLISH		RD-40
POIDS EN ORDRE DE MARCHÉ	WORKING WEIGHT	Kg	86
LONGUEUR SYSTÈME DE FRAPPE	CYLINDER LENGHT	mm	655
LONGUEUR TOTALE	TOTAL LENGHT	mm	1115
DEBIT D'HUILE	REQURED OIL FLOW	L/min	15-30
PRESSION DE TRAVAIL	WORKING PRESSURE	Bar	90-120
COUPS/MINUTE	IMPACTE RATE	bpm	800-1400
DIAMETRE OUTIL	CHISEL LENGHT	mm	40
CONNECTION FLEXIBLES	HOSE DIAMETER	inch	1/2
PRESSION PISTON ACCUMULATEUR	BACK HEAD PRESSUR	kg/cm2	14/17
POIDS DU PORTEUR	APPLICABLE EXCAVATOR	tonne	0,8-1,5
FORCE D'IMPACT	IMPACT POWER	Joule	130