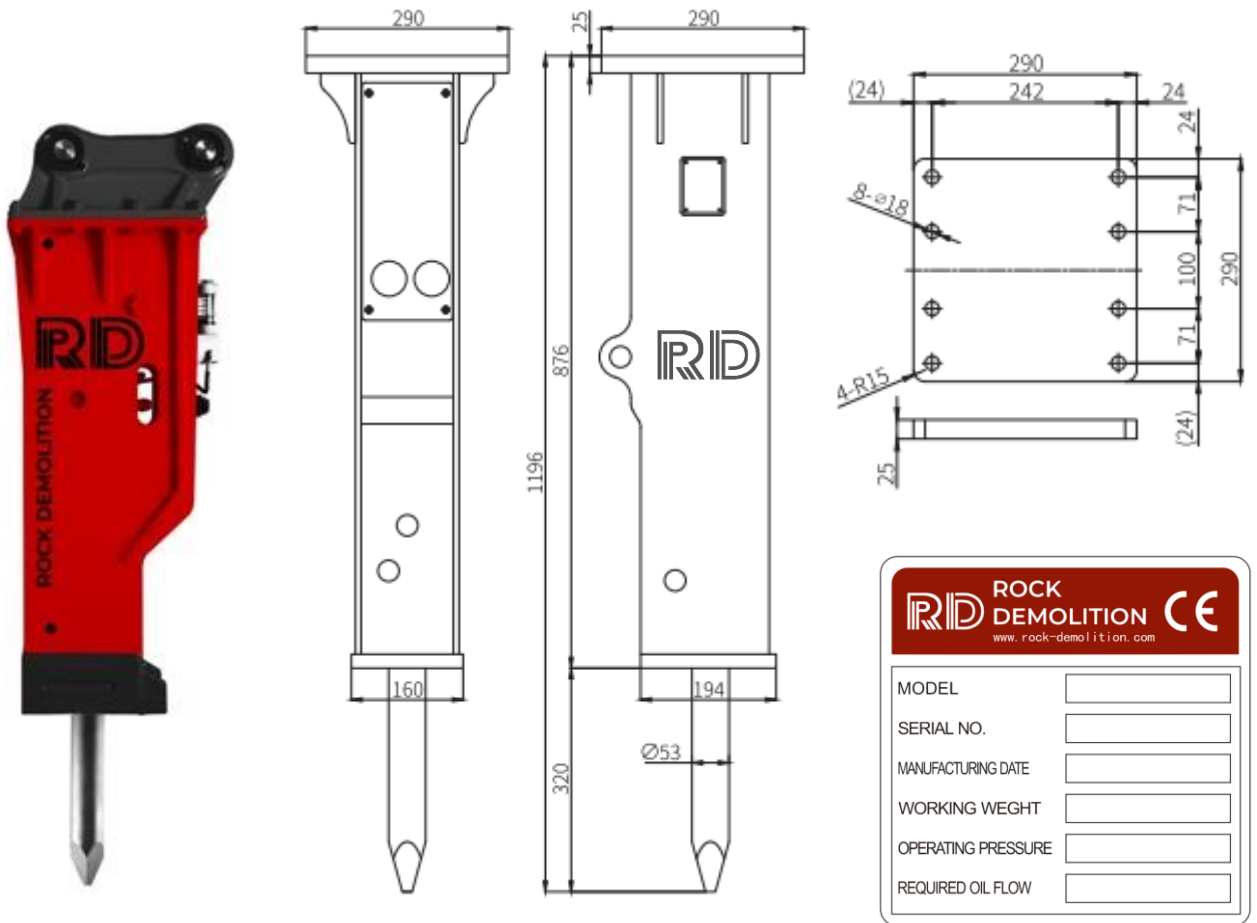

**RD-53**

## Spécifications technique

FRANCAIS	ENGLISH		<b>RD-53</b>
POIDS EN ORDRE DE MARCHÉ	WORKING WEIGHT	Kg	<b>180</b>
LONGUEUR SYSTÈME DE FRAPPE	CYLINDER LENGHT	mm	<b>823</b>
LONGUEUR TOTALE	TOTAL LENGHT	mm	<b>1446</b>
DEBIT D'HUILE	REQUIRED OIL FLOW	L/min	<b>20-50</b>
PRESSION DE TRAVAIL	WORKING PRESSURE	Bar	<b>90-120</b>
COUPS/MINUTE	IMPACTE RATE	bpm	<b>700-1100</b>
DIAMETRE OUTIL	CHISEL LENGHT	mm	<b>53</b>
CONNECTION FLEXIBLES	HOSE DIAMETER	inch	<b>1/2</b>
PRESSION PISTON ACCUMULATEUR	BACK HEAD PRESSUR	kg/cm2	<b>14/17</b>
POIDS DU PORTEUR	APPLICABLE EXCAVATOR	tonne	<b>2.5-5</b>
FORCE D'IMPACT	IMPACT POWER	Joule	<b>260</b>