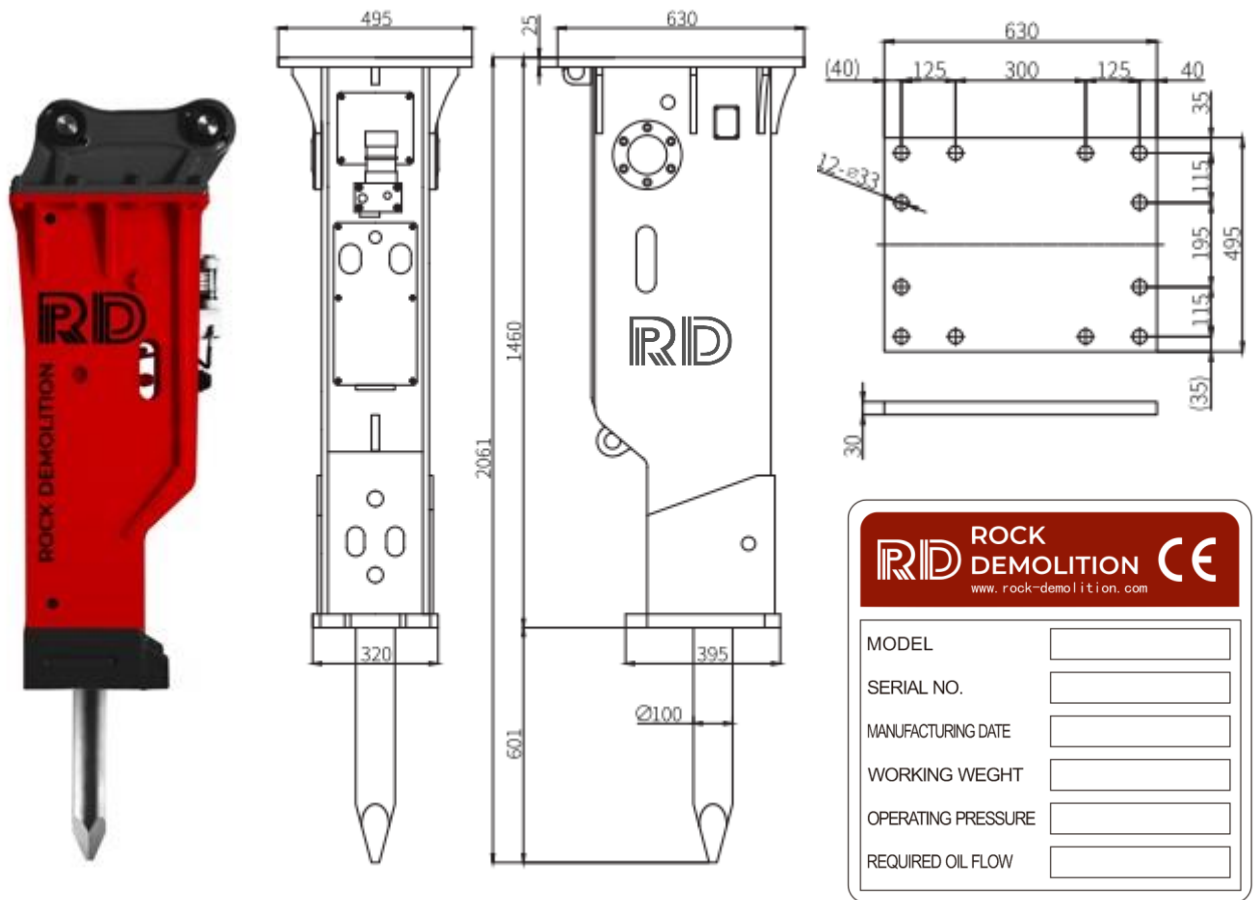

**RD-100**

Spécifications technique

FRANCAIS	ENGLISH		RD-100
POIDS EN ORDRE DE MARCHÉ	WORKING WEIGHT	Kg	986
LONGUEUR SYSTÈME DE FRAPPE	CYLINDER LENGHT	mm	1373
LONGUEUR TOTALE	TOTAL LENGHT	mm	2310
DEBIT D'HUILE	REQUIRED OIL FLOW	L/min	80-110
PRESSION DE TRAVAIL	WORKING PRESSURE	Bar	150-170
COUPS/MINUTE	IMPACTE RATE	bpm	350-700
DIAMETRE OUTIL	CHISEL LENGHT	mm	100
CONNECTION FLEXIBLES	HOSE DIAMETER	inch	3/4
PRESSION PISTON ACCUMULATEUR	BACK HEAD PRESSUR	kg/cm2	14/17
POIDS DU PORTEUR	APPLICABLE EXCAVATOR	tonne	10-16
FORCE D'IMPACT	IMPACT POWER	Joule	1960